

# OWNER'S MANUAL

**Model: DMS-3PT-12V-4.5  
(5302045)**

**(4.5 Cubic Ft., 3-Point  
Dry Material Spreader)**

## Technical Specifications

- Hopper Capacity: 4.5 Cu. Ft.
- Spread Width: 5' to 45'
- 12 Volt Motor w/Variable Speed Control (VSC)
- Stainless Steel 6-Blade Radial Fan
- Holds Up To 220 lbs. Potash or 200 lbs. Urea

### Approved for:

- ◆ Fertilizer ◆ Seed ◆ Bait ◆ Pellets
- ◆ Ice Melting Pellets ◆ Granular Insecticides, Fungicides & Herbicides

**Not Recommended for Rock Salt or Sand**

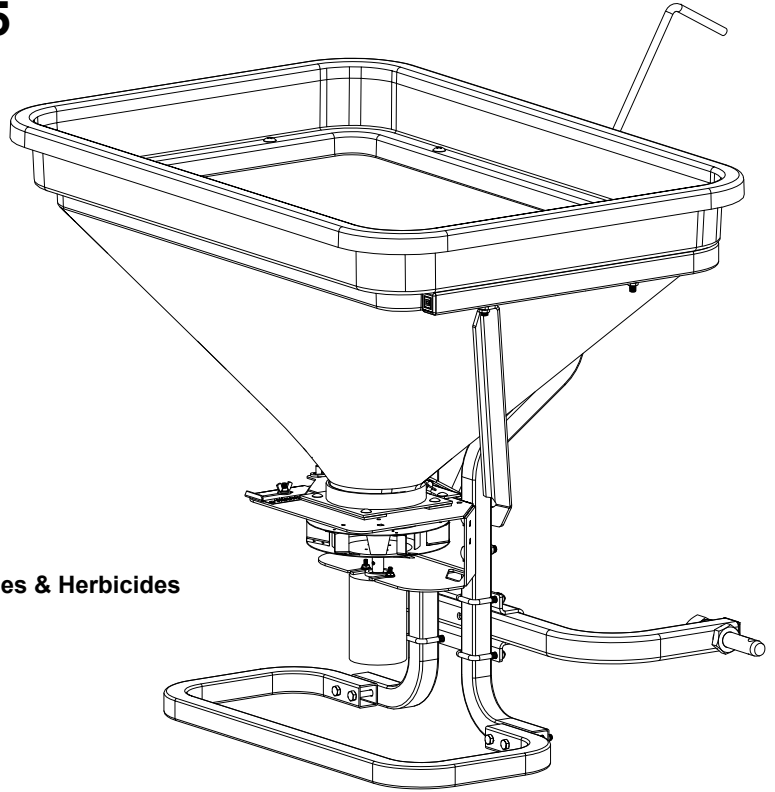

**BEFORE RETURNING THIS PRODUCT  
FOR ANY REASON, PLEASE CALL**

**1-800-831-0027**

**IF YOU SHOULD HAVE A QUESTION OR  
EXPERIENCE A PROBLEM WITH YOUR  
FIMCO INDUSTRIES PRODUCT:**

**1-800-831-0027**

**BEFORE YOU CALL, PLEASE HAVE THE  
FOLLOWING INFORMATION AVAILABLE:  
SALES RECEIPT & MODEL NUMBER. IN MOST  
CASES, A FIMCO INDUSTRIES EMPLOYEE CAN  
RESOLVE THE PROBLEM OVER THE PHONE.**

## Operating Safely

Read this owner's manual before you assemble or operate the Dry Material Spreader.

Use eye, hand and breathing protection appropriate to the materials that you are spreading. Read the manufacturers or suppliers labels for proper protective equipment.

Read and follow the manufacturer's instructions and notes for spreading and handling materials used for spreading.

Do not allow anyone to ride on or sit with you while operating the spreader.

Do not modify Dry Material Spreader or safety devices and guards.



**WARNING:** To reduce the risk of injury, the user must read and understand the operator's manual before using this product.



**WARNING:** Cancer and Reproductive Harm  
[www.P65Warnings.ca.gov](http://www.P65Warnings.ca.gov)

## General Information

Thank you for purchasing this product. The purpose of this manual is to assist you in operating and maintaining your dry material spreader.

**Retain a copy of your receipt for your unit,  
as it will be required to validate any warranty service**  
**Products are warranted against manufacturer or workmanship  
defects for one year from date of purchase for home owner  
usage and 90 days for commercial usage.**

For technical assistance, visit our website @ [www.fimcoindustries.com](http://www.fimcoindustries.com) or call: **TOLL FREE @ 1-800-831-0027**  
Our Technical Support Representatives will be happy to help you.  
To obtain prompt, efficient service, always remember to give the following information...

- Correct Part Description and/or part number
- Model #/Serial # of your sprayer

Part descriptions and numbers can be obtained from the illustrated parts list section(s) of this manual.

**FIMCO**  
I N D U S T R I E S

**[www.fimcoindustries.com](http://www.fimcoindustries.com)**

1000 FIMCO Lane, P.O. Box 1700, North Sioux City, SD 57049  
Toll Free Phone: 800-831-0027 : Toll Free Fax: 800-494-0440

[5008320

(10/18)]

## Assembly Instructions

- Remove all parts and hardware packages from the carton. Lay out all parts and hardware and identify using the illustrations later in this manual
- Any additional assembly of loose parts should be assembled onto the spreader per the exploded view drawing.

### Installation

- Attach the spread to your 3-point hitch and secure in place.
- Use 12V motor controller (battery cable) clip to connect directly to the battery. Connect to the red clip (wire) to the positive (+) terminal first, then connect the black clip (wire) to the negative (-) terminal.
- Route 12V motor controller battery cable and 12V motor controller (motor cable) securely and carefully to prevent damage from moving parts and exhaust heat.
- Turn the Motor Controller switch to the OFF position before connecting to motor cable.
- Set the Motor Controller to the number "5" and switch the fan motor on. The fan should run at ½ speed. Rotate to number "10" for full fan speed and then rotate to number "1" for slowest fan speed.

This should be done without material in the hopper and the slide gate closed.

When disconnecting, make sure Motor Controller switch is OFF, disconnect the motor cable from the motor. Then disconnect the negative (black) connection and finally the positive (red) connection.

### Operation

Replace or repair loose or missing components. Operate controls and switches to make sure they respond correctly. Conditions of weather and terrain must be considered when setting spreader. Do not spread on windy days, with light weight materials, such as grass seed. Protective clothing must be worn in some cases.

#### 1. Determine vehicle speed:

If vehicle does not have a speedometer, determining speed can be accomplished by marking off 100, 200 or 300 feet.

The speed chart indicates the number of seconds it takes to travel the distances.

Using a watch or stop watch for time, travel into and out of the marked distance for a more accurate application speed.

See the recommended speeds/settings later in this manual.

$$\text{SPEED (MPH)} = \text{Distance (Ft.)} \times 60 / \text{Time (seconds)} \times 88$$

Speed Chart			
Speed in M.P.H. (Miles Per Hour)	Time Required in seconds to travel a distance of		
	100 Ft.	200 Ft.	300 Ft.
1.0	68 sec.		
2.0	34	68	102
3.0	23	45	68
4.0	17	34	51
5.0	14	27	41
6.0	11	23	34
7.0	9.7	19	29
8.0	8.5	17	26
9.0	7.6	15	23
10.0	6.8	14	20

#### 2. Set Electronic Speed Control:

Adjust speed control to set the spread width. The highest fan speed will spread the widest pattern.

After adjusting the speed control to the desired width for the material you are using. Leave the dial on this setting and use the power switch to turn the fan on and off.

#### 3. Set Opening Gauge Control:

Refer to the settings chart for the proper settings.

Loosen wing nut and move gate slide gauge to the desired setting. Tighten wing nut.

#### 4. Adjust Pattern Adjust Ring Position to Center Spread Pattern:

If the spread pattern is off-center, adjust by rotating the pattern adjusting ring. This adjustment is only required if the material density has dramatically changed.

Pattern adjust ring has been set at the factory for UREA.

**CAUTION:** Making adjustments with spinner running is unsafe. Never adjust pattern ring with spinner powered. Make sure motor controller switch is OFF and disconnect the motor cable from the motor before doing any pattern adjusting.

◆ Loosen worm gear clamp only enough to allow pattern adjust ring to be removed with slight force.

◆ Adjust pattern ring to re-center spread pattern:

If pattern is too heavy to the driver's right, rotate the pattern adjust ring clockwise (as viewed from the top) until the pattern is even.

If pattern is too heavy to the driver's left, rotate the pattern adjust ring counter-clockwise (as viewed from the top) until the pattern is even.

Retighten the worm gear clamp to a snug fit. **DO NOT OVERTIGHTEN!**

**NOTE:** To return the pattern adjust ring to the factory setting, simply align the pattern adjust ring to the center of the mounting plate, as pictured below (\*\*).

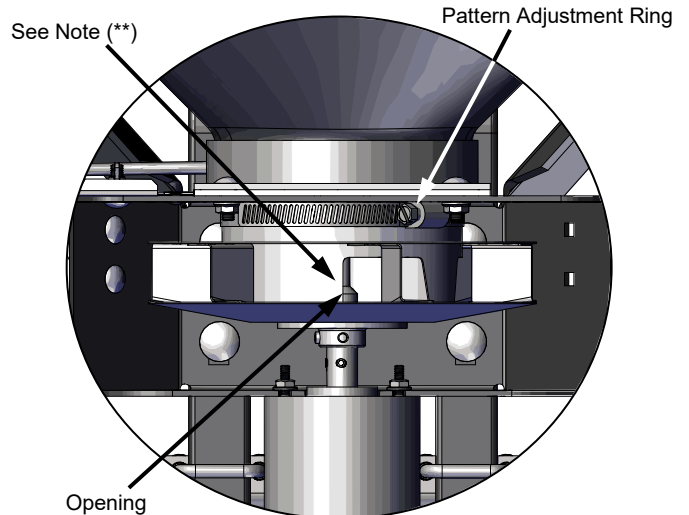

Do not fill and transport over long distances. This will result in material packing and caking. Remove and clean all material at the end of your spreading day.

### Cleaning/Storing

- Remove and clean all material from the hopper.
- Rinse inside and outside of hopper and dry before storing.
- Motor and Motor Controller are NOT water resistant. Do Not submerge into water or use high pressure sprayers to clean.
- The spreader should be stored in a dry area.

Exploded View  
 DMS-3PT-12V-4.5  
 (5302045)

Refer to Parts List on Next Page  
 for Part Numbers

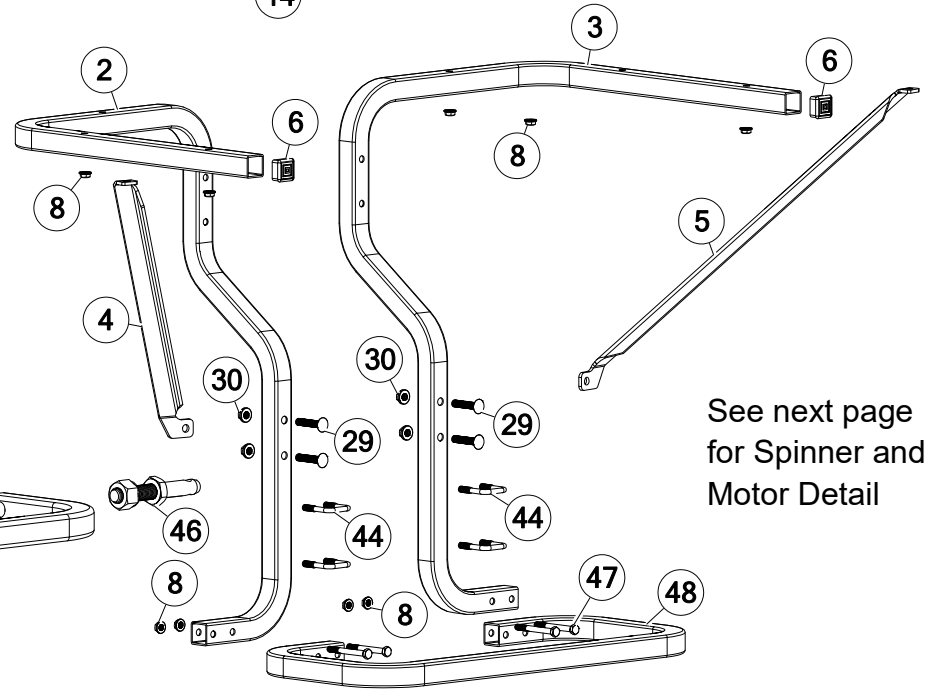
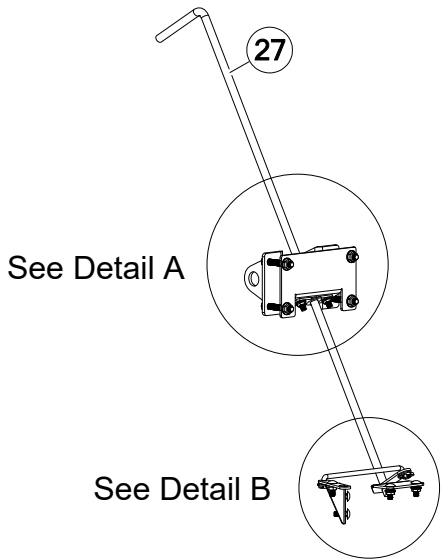
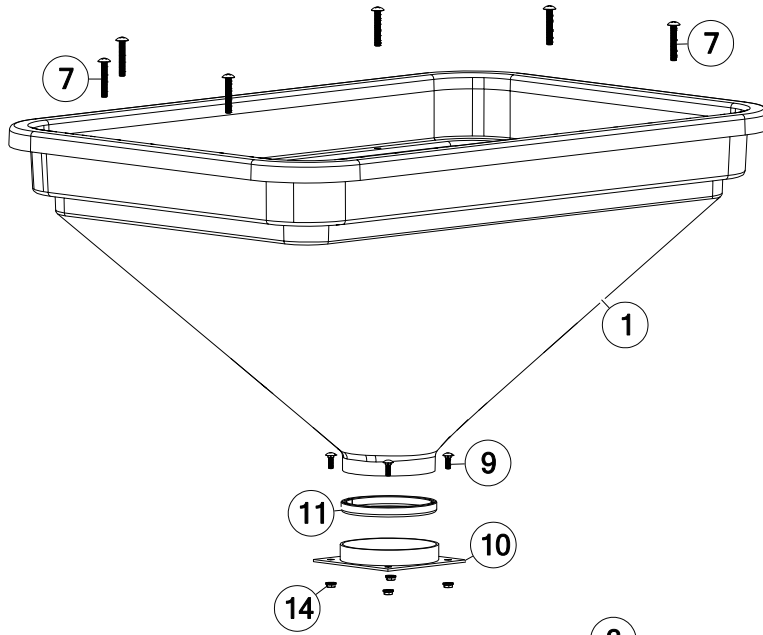

See next page  
 for Spinner and  
 Motor Detail

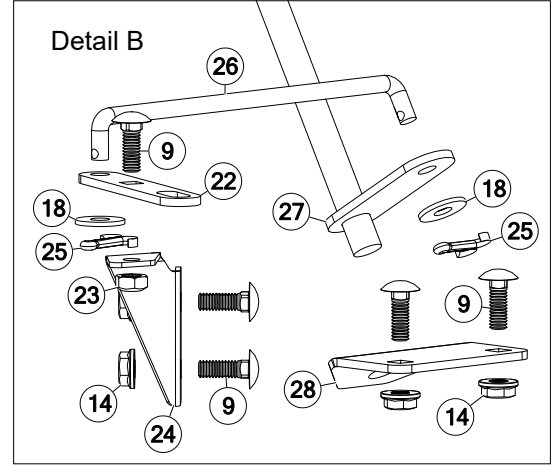
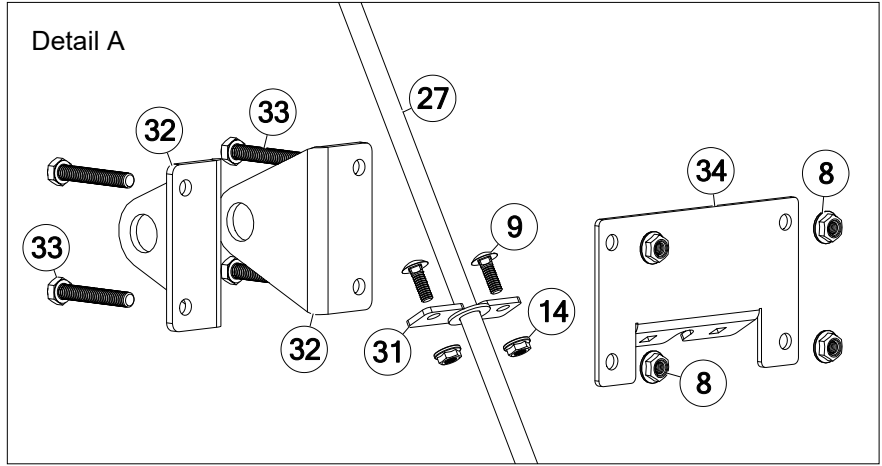
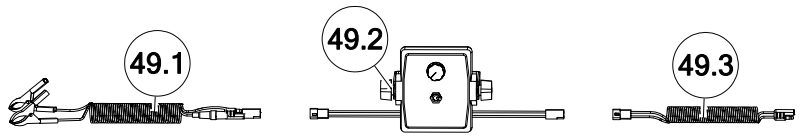

# Spinner/Motor Detail

See Parts List Below for Part Numbers

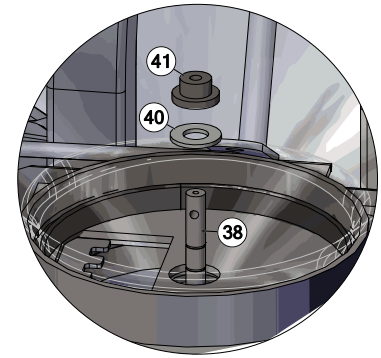
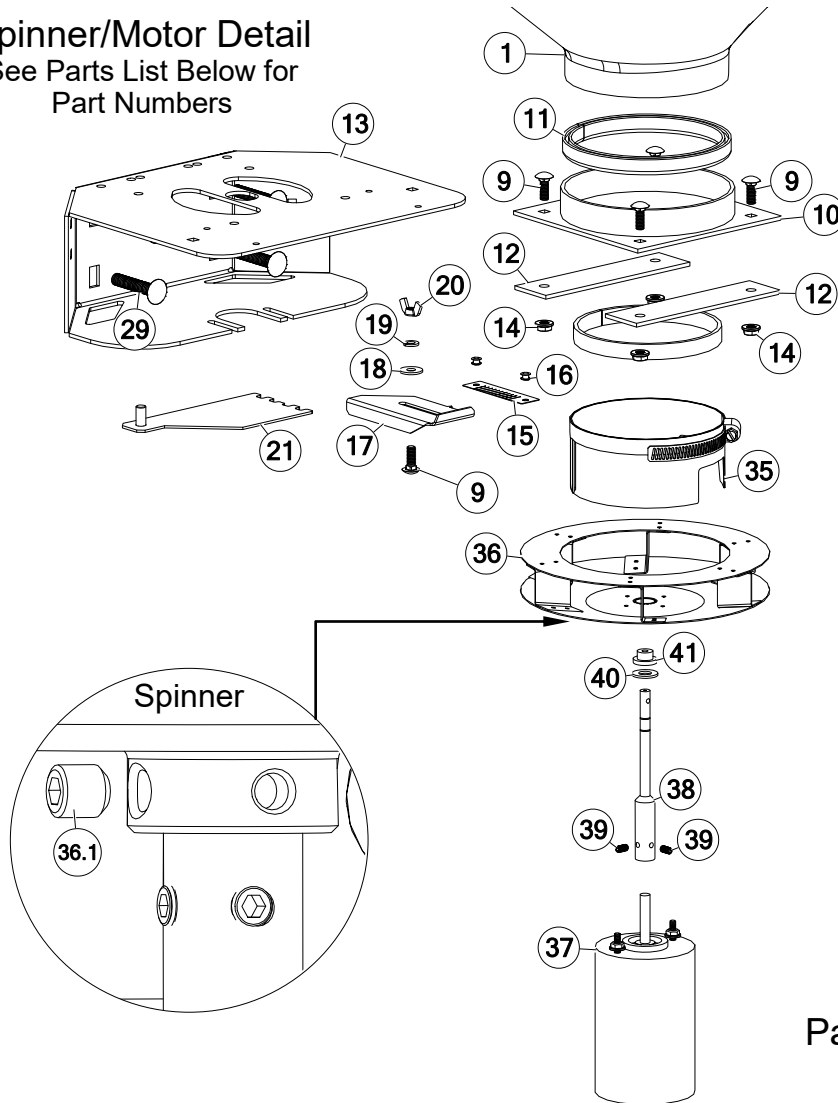

Inside Hopper:  
Spindle (Item 38) comes up through the base plate weldment. Washer (Item 40) is held down to base plate by Grommet (Item 41), to keep material from falling out around spindle.

An agitation clip (pin), not included, is not necessary with this unit. If you find you need one with some materials, you can use a hairpin cotter pin through the hole in the spindle.

## Parts List: DMS-3PT-12V-4.5 (5302045)

Ref. #	Part #	Description	Qty
1	5083008	4.5 Cu./Ft Hopper	1
2	5070079	L.H. 4.5 Cu-Ft Hopper Frame	1
3	5070080	R.H. 4.5 Cu-Ft Hopper Frame	1
4	5037749	Angle Brace L.H.	1
5	5037748	Angle Brace R.H.	1
6	5046344	Square Cap, Black (1 1/4" Square)	2
7	5117321	Truss Head Machine Screw 5/16"-18 x 2"	6
8	5006307	5/16-18 Serrated Flng Hex Nut, Grade A	22
9	5034481	SS Carriage Bolt, 1/4"-20 x 3/4"	12
10	5275923	Hopper Base/Ring Plate Weldment	1
11	5194390	15 1/2" Long Trim-Lok	1
12	5127198	Plastic Spacer/Guide	2
13	5277419	Spinner Housing Weldment	1
14	5006306	1/4-20 Serrated Flng Hex Nut, Grade A	11
15	5027132	Gate Scale Plate	1
16	5111025	Rivet, 3/16" Dia. x 3/8" Long	2
17	5131073	Gate Stop	1
18	5016300	SS Flatwasher - 1/4" x .625" OD	3
19	5016309	Spring Lockwasher 1/4"	1
20	5006358	1/4-20 Wing Nut, SAE 316, SS	1
21	5277412	Slide Gate Weldment	1
22	5092027	Gate Pivot	1
23	5006160	1/4-20 Top-Lock Hex Nut, Grade C	1
24	5095276	Gate Pivot Mount	1
25	5101077	Cotter Pin, 1/8" x 1"	2
26	5094036	Gate Linkage	1
27	5277411	Gate Lever Weldment	1
28	5095278	Pivot Mount	1

Ref. #	Part #	Description	Qty
29	5034485	3/8"-16nc x 2" (Full Thread) Carriage Bolt	4
30	5006259	3/8-16 Serrated Flng Hex Nut, Grade A	4
31	5027318	Handle Mount Plate	1
32	5095277	Upper Hitch Mount	2
33	5034082	H.H.C.S. 5/16"-18nc x 2" (Full Thread)	4
34	5027316	Tie Plate	1
35	5275924	Pattern Adjusting Ring Weldment	1
36	5160003	Spinner	1
36.1	5117316	B18.3.6M - M6 x 1.0 x 6 Hex Socket Flat Pt. SS	1
37	5275840	12 Volt Motor 5/16" Dia Shaft	1
37.1	5006186	#10-24 Serrated Flng Hex Nut, Grade A	2
38	5024115	Dry Spreader Motor Spindle	1
39	5117326	M5 x .8 x 10 Long Hex Socket Flat Pt. S.S.	2
40	5016030	Flatwasher - 3/8" x 1" OD	1
41	5075020	Grommet/Dry Spreader	1
42	5100694	2-Point Pick Up Tube	1
43	5051142	Tube Clamp	1
44	5034159	5/16-18 x 1.3125 x 1.875 Square U-Bolt, Grade 2	4
45	5046425	Square Cap, Black (1 1/2" Square)	2
46	5101294	Lift Arm Pin - Cat 1	2
47	5034644	H.H.C.S., 5/16"-18 x 3"	4
48	5165025	Frame Stand	1
49	5275918	12V Motor Controller Set	1
49.1	5157210	12V Motor Controller (Battery Cable)	1
49.2	5157208	Motor Controller (12 Volt, 10 Amp)	1
49.3	5157211	12V Motor Controller (Motor Cable)	1

## Approximate Unit Dimensions:

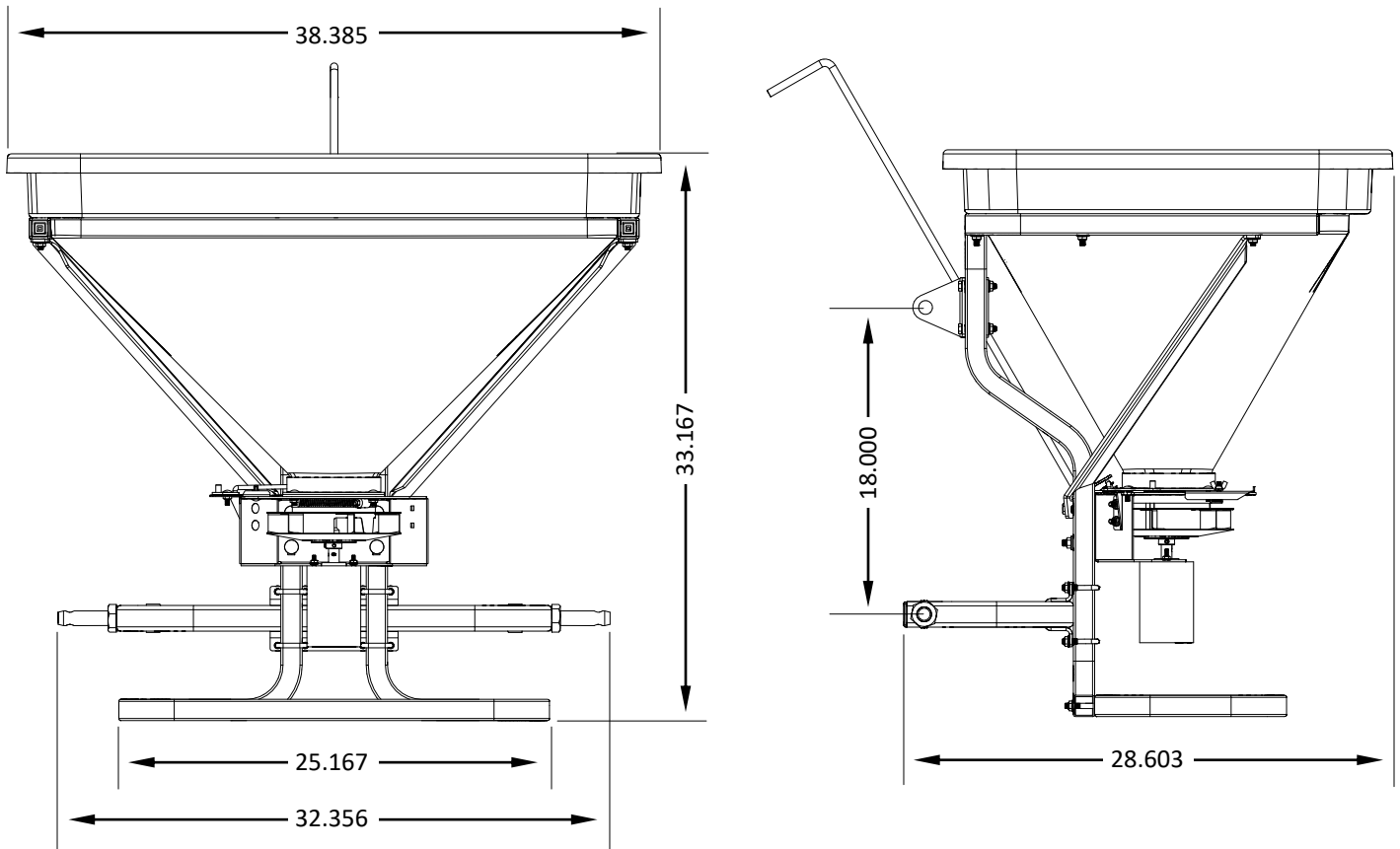

An agitation clip (pin), not included, is not necessary with this unit. If you find you need one with some materials, you can use a hairpin cotter pin through the hole in the spindle.

Troubleshooting Guide		
Symptom	Possible Cause	Action
Spreader Motor Does Not Run	1. Loose or corroded connection	1. Clean, check and reconnect
	2. Speed Control Light is OFF	2. Check fuse. Replace if necessary
	3. Loose battery connection	3. Adjust battery clamp contact
	4. Broken spreader wiring	4. Replace or repair damaged wiring
	5. Over or Under voltage	5. Power to harness connected to aux. circuit; Connect direct to battery
	6. Controller is not functioning	6. Bypass the controller, by connecting the wires together
Erratic Spread Pattern	Spinner Shaft Set Screws Loose	Tighten Set Screws
Gate will not close or open	Fertilizer around Slide Gate	Remove slide gate and clean after emptying hopper of material
Gate will not stay open or closed	1. Friction washer is lost or worn	Replace friction washer
	2. Friction washer is in place	Bend slide gate arm up to tighten and down to loosen gate action.

# Settings & Charts

<b>Grass (3 MPH &amp; 10' Spread Width)</b>			
lbs/1000 Sq. Ft.	lbs/per Acre	Gate Setting	Materials
5-10	220-440	7.5-9.5	Bahia Grass
.80-1.49	35-65	1-1.5	Bentgrass
2.5-5	110-220	3-7.5	Bermudagrass
.18-.28	8-12	.5	Big Bluestem
.28-.46	12-20	2	Bromegrass
2-3	85-130	3-4	Buffalograss
4-5	175-220	7-7.5	Carpetgrass
.5-1	25-45	.75-2.5	Centipedegrass
.11-.18	5-8	.25	Chicory
3-8	125-200	4-9.5	Creeping Red Fescue
.18-.28	8-12	.5	Eastern Gamagrass
.46-.69	20-30	1	Festulolium
.22-.34	10-15	.5	Indiangrass
2-6	100-175	3-8	Kentucky Bluegrass-Lawn
.46-.69	20-30	1	Kentucky Bluegrass-Pasture

<b>Grass (3 MPH &amp; 10' Spread Width)</b>			
lbs/1000 Sq. Ft.	lbs/per Acre	Gate Setting	Materials
3-8	125-300	4-9.5	Lawn Mixtures
.34-.46	15-20	.75	Orchardgrass
.18-.28	8-12	.5	Reed Canary Grass
.11-.18	5-8	.25	Red Fescue
.18-.28	8-12	.5	Red Top
.57-.69	25-30	2	Ryegrass-Annual
.57-.69	25-30	2	Ryegrass-Perennial
5-8	200-325	7.5-9.5	Ryegrass Fine Leaved Perennial
.18-.28	8-12	.5	Switchgrass
.69-.80	30-35	1	Sudan Grass
.22-.28	10-12	.5	Timothy-Grass
.34-.46	15-20	1.5	Tall Fescue
5-8	200-325	7.5-9.5	Turf Type Fescue-Lawn
1-2	45-85	2.5-3	Zoysia

<b>Turf Materials (3 MPH &amp; 20' Spread Width)</b>		
lbs/1000 Sq. Ft.	Gate Setting	Materials
10	6.5	All America All Purpose Fertilizer 10-10-10
3	4.5	Bayer Season Long Grub Control
2.4	4	Bayer Season Long Grub Control
3	4	Bayer Complete Insect Killer
2	3.5	Bayer Complete Insect Killer
3	3	Bayer Power Force Multi-Insect Killer
2	2.5	Bayer Power Force Multi-Insect Killer
4	4	EC Grow Premier Turf Fertilizer 25.3-10
3	4	Eliminator Ant, Flea & Tick Killer Granules
2.5	3.5	Eliminator Ant, Flea & Tick Killer Granules
2	3.5	Eliminator Ant, Flea & Tick Killer Granules
2	3.5	Eliminator Fire Ant Killer Granules
2	4	Eliminator 5% Diazinon Killer Granules
7	5.5	Howard Johnsons All Purpose Fertilizer 8-8-8
7	5.5	Howard Johnsons All Purpose Fertilizer 10-10-10
7	5.5	Howard Johnsons All Purpose Fertilizer 12-12-12
5	5	Ironite 1-0-0
4	4	Klay Soft Pelletized Gypsum Soil Conditioner
3	3.5	Klay Soft Pelletized Gypsum Soil Conditioner
2	3	Klay Soft Pelletized Gypsum Soil Conditioner
4	5	Lesco Pre-M 0.86% Plus Fertilizer 25-0-7
4.2	4.5	Lesco Starter Fertilizer 18-24-12
4.2	4	Lesco Turf Fertilizer 24-2-11
4	4	Lesco Weed & Feed
8	7	Milorganite 6-2-0
16	8.5	Milorganite 6-2-0
3.2	4	Miracle-Gro Lawn Fertilizer Plus Weed Control 26-3-3
3.6	4	Miracle-Gro Starter Lawn Fertilizer 20-27-5
3.1	3.5	Miracle-Gro Starter Lawn Fertilizer 29-3-4
9.6	6	Ortho Lawn Insect Granules
4.8	4	Ortho Lawn Insect Granules
2.4	2.5	Ortho Lawn Insect Granules
1.2	2	Ortho Lawn Insect Granules
4	4.5	Ortho Max Insect Killer for Lawns
2	3.5	Ortho Max Insect Killer for Lawns
1	2.5	Ortho Max Insect Killer for Lawns
10	6.5	Parkers Super Soilite Lawn & Garden Fertilizer 10-10-10
6.5	5	Parkers Super Soilite Lawn & Garden Fertilizer 16-4-8
3.6	4	Pennington Lawn Starter Fertilizer 18-24-6

<b>Turf Materials (3 MPH &amp; 20' Spread Width)</b>		
lbs/1000 Sq. Ft.	Gate Setting	Materials
2	3	Real-Kill Multi-Purpose Lawn & Garden Insect Killer
2.5	3.5	Real-Kill Multi-Purpose Lawn & Garden Insect Killer
10	7.5	Ringer Lawn Restore 10-2-6
12.3	8	Sam's Choice Crabgrass Preventer 30-3-4
8.1	6.5	Sam's Choice Crabgrass Preventer 30-3-4
6	6	Sam's Choice Crabgrass Preventer 30-3-4
5.4	5.5	Sam's Choice Crabgrass Preventer 30-3-4
3	3.5	Sam's Choice Insect Control Plus Fertilizer 28-4-6
3.2	4	Sam's Choice Lawn Food 29-3-4
6	6	Sam's Choice Starter Fertilizer 20-27-5
3.6	4.5	Sam's Choice Starter Fertilizer 20-27-5
2.3	3	Scotts Grubex
3.1	4.5	Scotts Grubex Season Long Grub Control
2.3	4	Scotts Grubex Season Long Grub Control
1.4	3	Scotts Lawn Fungus Control
2.7	4.5	Scotts Lawn Fungus Control
3.6	4	Scotts Starter Fertilizer 20-27-5
5.9	5	Scotts Starter Fertilizer 20-27-5
2.7	4	Scotts Turf Builder 28-3-8
3.1	3.5	Scotts Turf Builder Lawn Fertilizer 29-3-4
2.7	4	Scotts Turf Builder w/Summer Guard
2.9	4	Scotts Turf Builder Plus Weed Control
4.7	4.5	Scotts Winterizer 24-3-12
3.3	4	Scotts Winterizer 24-3-12
4.6	5	Sevin Lawn Insect Granules
2.33	4	Sevin Lawn Insect Granules
2.25	4	Sevin Lawn Insect Granules
3	4.5	Spectracide Grub Stop
3	2.5	Spectracide Triazicide Insect Killer Granules
3.6	4	Sta-Green Lawn Fertilizer 29-2-5
2	3.5	Sta-Green Lawn Weed Control
3.2	4	Sta-Green 200 Plus Weed & Feed 28-3-3
3.6	4	Sta-Green Starter Fertilizer 18-24-10
3.2	4	Sta-Green Weed & Feed 28-2-4
3	2.5	Vigoro Insect Control Plus Fertilizer
3.6	5	Vigoro Starter Fertilizer
3.5	4	Vigoro Turf Fertilizer 29-3-4
3	3.5	Vigoro Ultra Turf Winterizer 22-3-14
3.2	5	Vigoro Weed & Feed
3.2	4	Wal Mart Weed & Feed 28-3-3



This is information off the sticker on the hopper.

lbs./1000 Sq. Ft.	0.6	0.7	0.8	1	1.5	2	3.5	4.5	6.0	7.5	9.0	10.0	11.0	13.0	15.0	17.0
Flow Control Setting	1	2	2.5	3	3.5	4	4.5	5	5.5	6	6.5	7	7.5	8	9	10
Operation Instructions	* USE APPLICATION INFORMATION ON BAG, FIND CALIBRATION SETTING (ABOVE) AND SET GATE STOP TO CORRECT FLOW SETTING * IF SPREAD PATTERN IS OFF CENTER ADJUST PATTERN RING POSITION, SEE OWNER'S MANUAL * NOTE: ABOVE CALIBRATION SETTINGS HAVE BEEN DETERMINED USING UREA 46-0-0, 20 FOOT SWATH & 3 MPH (TRAVEL 88 FT. IN 20 SECONDS) * NOTE: CALIBRATION GUIDE SETTINGS IS TO BE USED AS A GENERIC GUIDE. FOR SPECIFIC PRODUCTS, SEE YOUR OWNER'S MANUAL															
Instrucciones De Operacion	* USE LA INFORMACIÓN SOBRE APLICACIÓN EN LA BOLSA, BUSQUE LA POSICIÓN LA CALIBRACIÓN (ARRIBA) Y FIJE LA PARADA DE LA PUERTA PARA CORREGIR LA CALIBRACIÓN DE LA CORRIENTE. * SI PAUTA de EXTENSIÓN ES DE el CENTRO AJUSTA POSICIÓN de ANILLO de PAUTA VE MANUAL. * NOTA: ENCIMA DE CALIBRACIÓN AJUSTES HA SIDO DETERMINADO UTILIZAR 46-0-0 de UREA, 20 de RINGLERA de PIE, Y 3 MPH (VIAJA 88 P EN 20 SEGUNDOS). * NOTA: AJUSTES de GUÍA de CALIBRACIÓN SON de SER UTILIZADOS COMO UNA GUÍA GENÉRICA. PARA PRODUCTOS ESPECÍFICOS, VEA SU MANUAL.															

## Warranty

### LIMITED WARRANTY FOR NEW FIMCO, IND. EQUIPMENT

**WHO MAY USE THIS LIMITED WARRANTY.** This limited warranty (the "Limited Warranty") is provided by Fimco, Ind. to the original purchaser ("you") of the Equipment (as defined below) from Fimco, Ind. or one of Fimco, Ind.'s authorized dealers. This Limited Warranty does not apply to any subsequent owner or other transferee of the Equipment. THIS LIMITED WARRANTY GIVES YOU SPECIFIC LEGAL RIGHTS, AND YOU MAY ALSO HAVE OTHER RIGHTS WHICH VARY FROM STATE TO STATE.

**WHAT THIS LIMITED WARRANTY COVERS AND FOR HOW LONG.** Fimco, Ind. warrants that any new Equipment will be free from defects in material and workmanship for a period of **one (1) year** (homeowner), **90 days** (commercial user), after delivery of the Equipment to you (the "Warranty Period"). The Warranty Period is not extended if Fimco, Ind. repairs or replaces the Equipment.

**WHAT IS NOT COVERED BY THIS LIMITED WARRANTY.** This Limited Warranty does not apply to: (1) used Equipment; (2) any Equipment that has been altered, changed, repaired or treated since its delivery to you, other than by Fimco, Ind. or its authorized dealers; (3) damage or depreciation due to normal wear and tear; (4) defects or damage due to failure to follow Fimco, Ind.'s operator's manual, specifications or other written instructions, or improper storage, operation, maintenance, application or installation of parts; (5) defects or damage due to misuse, accident or neglect, "acts of God" or other events beyond Fimco, Ind.'s reasonable control; (6) accessories, attachments, tools or parts that were not manufactured by Fimco, Ind., whether or not sold or operated with the Equipment; or (7) rubber parts, such as tires, hoses and grommets.

**HOW TO OBTAIN WARRANTY SERVICE.** To obtain warranty service under this Limited Warranty, you must (1) provide written notice to Fimco, Ind. of the defect during the Warranty Period and within **thirty (30) days** after the defect becomes apparent or the repair becomes necessary, at the following address: Fimco, Ind., 1000 Fimco Lane, North Sioux City, SD 57049; and (2) make the Equipment available to Fimco, Ind. or an authorized dealer within a reasonable period of time. For more information about this Limited Warranty, please call: **800-831-0027**.

**WHAT REMEDIES ARE AVAILABLE UNDER THIS LIMITED WARRANTY.** If the conditions set forth above are fulfilled and the Equipment or any part thereof is found to be defective, Fimco, Ind. shall, at its own cost, and at its option, either repair or replace the defective Equipment or part. Fimco, Ind. will pay for shipping and handling fees to return the repaired or replacement Equipment or part to you.

**LIMITATION OF IMPLIED WARRANTIES AND OTHER REMEDIES.** THE REMEDIES DESCRIBED ABOVE ARE YOUR SOLE AND EXCLUSIVE REMEDIES, AND FIMCO, IND.'S SOLE LIABILITY, FOR ANY BREACH OF THIS LIMITED WARRANTY. TO THE EXTENT APPLICABLE, ANY IMPLIED WARRANTIES, INCLUDING, WITHOUT LIMITATION, THE IMPLIED WARRANTIES OF MERCHANTABILITY AND FITNESS FOR A PARTICULAR PURPOSE, SHALL BE LIMITED IN DURATION TO THE WARRANTY PERIOD, AND THE REMEDIES AVAILABLE FOR BREACH THEREOF SHALL BE LIMITED TO THE REMEDIES AVAILABLE UNDER THIS EXPRESS LIMITED WARRANTY. SOME STATES DO NOT ALLOW LIMITATIONS ON HOW LONG AN IMPLIED WARRANTY LASTS, SO THE ABOVE LIMITATION MAY NOT APPLY TO YOU. IN NO EVENT SHALL FIMCO, IND.'S LIABILITY UNDER THIS LIMITED WARRANTY EXCEED THE ACTUAL AMOUNT PAID BY YOU FOR THE DEFECTIVE EQUIPMENT, NOR SHALL FIMCO, IND. BE LIABLE, UNDER ANY CIRCUMSTANCES, FOR ANY CONSEQUENTIAL, INCIDENTAL, SPECIAL OR PUNITIVE DAMAGES OR LOSSES, WHETHER DIRECT OR INDIRECT. SOME STATES DO NOT ALLOW THE EXCLUSION OR LIMITATION OF INCIDENTAL OR CONSEQUENTIAL DAMAGES, SO THE ABOVE LIMITATION OR EXCLUSION MAY NOT APPLY TO YOU.